

# PAB-BD BEYOND

## Intelligent Barrier

**Dashou**<sup>®</sup>  
Parking System Expert

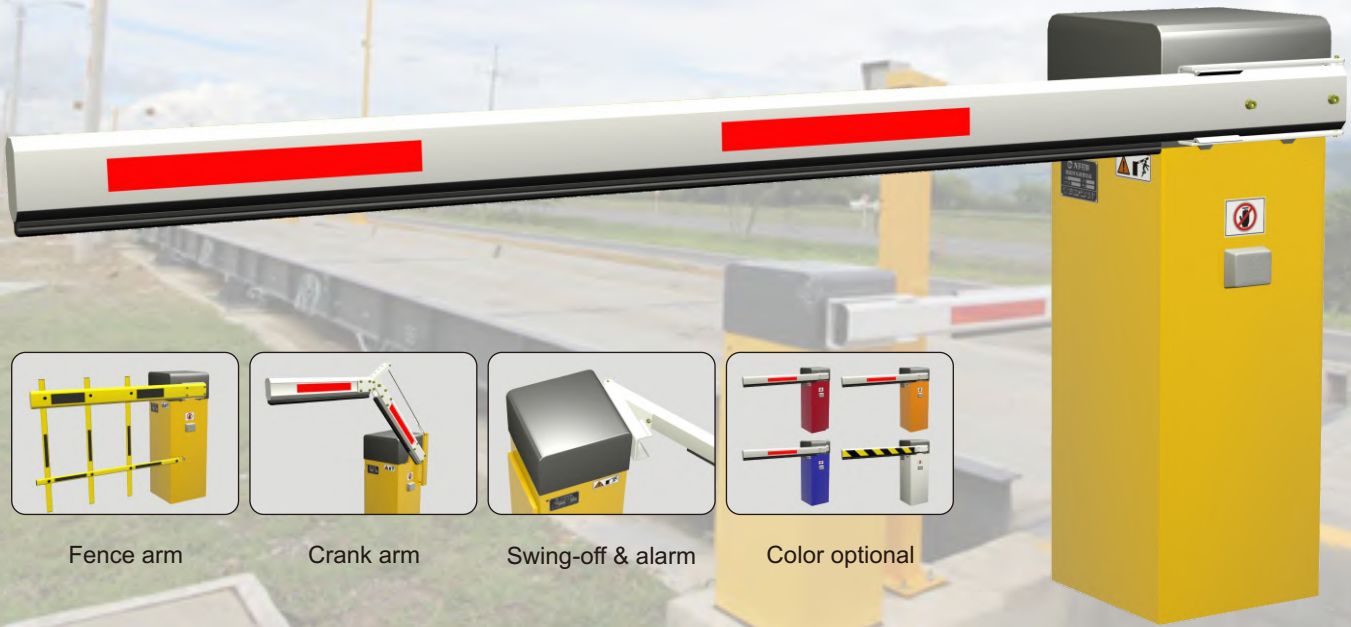

New generation barrier **PAB-BD BEYOND** adopts free-maintenance DC brushless torque motor and PWM variable frequency servo controller, fast but smooth moving. Incredible 10 million MCBF and 100% duty cycle makes it continuously work at 7\*24 hrs with long life span. Its boom direction is exchangeable, boom type can be changed at site without replacing any parts. Open/close time 0.9~6s adjustable, Max.6m boom. It can be controlled and programmed by smart phone via WIFI and by your own system via TCP/IP.

### Smartphone Control Your Barrier (Optional)

The barrier gate can be connected to your smartphone via WIFI, so you can open and close barrier gate on your smartphone. You can also program the barrier on your smartphone such as setting opening/closing time.

\*Dashou App should be installed in your smartphone, and Dashou WIFI module should be installed in barrier controller.

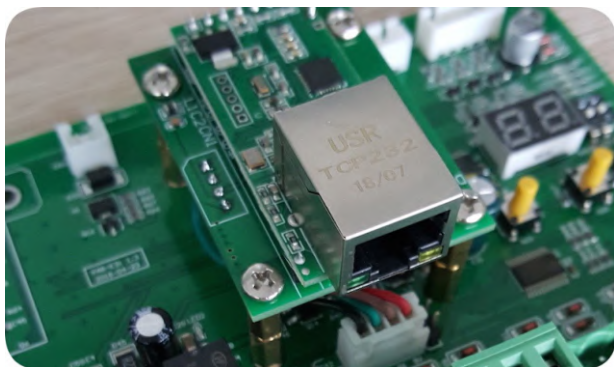

### TCP/IP Interface for Easy Integration (Optional)

The barrier provides optional TCP/IP RJ45 port, which can integrate the barrier with your own system conveniently, so you can control and monitor the barrier by your own system.

\*Dashou Ethernet module should be installed in barrier controller, and communication protocol will be provided by Dashou

## Free-maintenance DC Brushless Servo Motor 10 million cycles MCBF & 100% duty cycle

Free-maintenance DC24V brushless servo torque motor ensures 10 million cycles MCBF long life span; 100% duty cycle makes barrier continuously work at 24\*7 hours; Max. 50W super low consumption makes barrier environment friendly but outputs super strong torque



## Boom Direction Is Exchangeable Without Replacing Any Parts

In the past you have to keep stock for barriers with different boom direction as different sites may require different boom direction. But now boom arm direction can be exchanged easily at site without replacing any parts

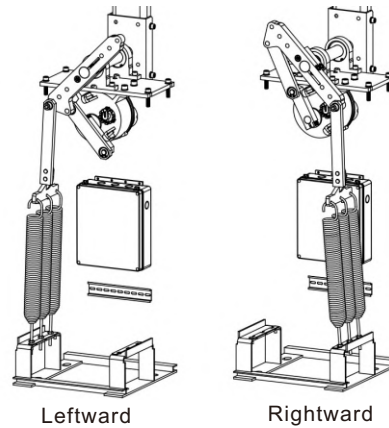

## Automatically Check Status and Report Error

Barrier system will automatically check its operation status and show errors code on its LED tube if an error occurred. This helps you quickly find out problem and find solution.

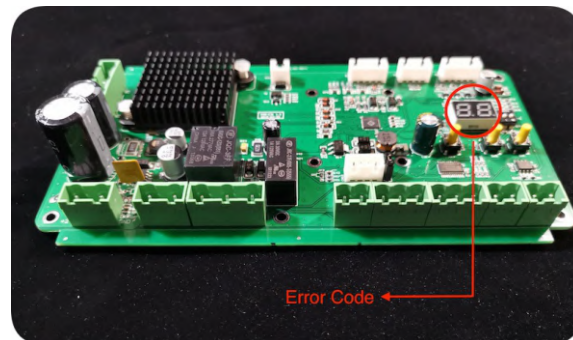

## Manually Control In Case of Power Failure

If power supply is off, you can manually open/close the barrier gate by the black lever. Also boom can be manually locked in any position between horizontal and vertical by this level.

Warning: Not allowed to use the function when power on, may hurt your hand and damage the motor.



## Boom Auto-Reverse On Obstacle

While moving down, boom will automatically reverse immediately once it is obstructed by vehicle or pedestrian, which protects the vehicle or person. The sensitivity is adjustable.



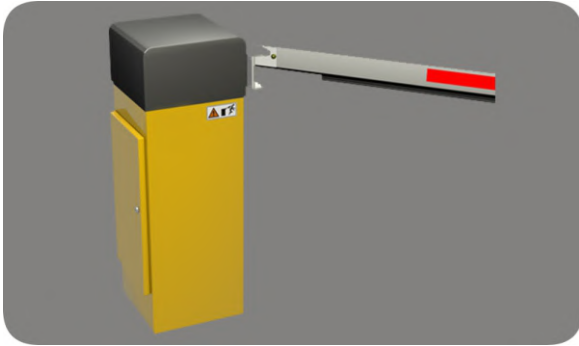

### Boom Swing-off Protects Boom and Vehicle

Boom will swing off 90 degree if it was hit by a vehicle, this is to protect both vehicle and boom. It is optional. You can easily add swing-off module to a barrier which is without swing-off.



### Backup Solar Panel or Lead-acid Cell

DC motor barrier can be powered by solar panel or lead-acid cell for back up power supply. Especially solar power is environment friendly which is good for earth.



### LED Illumination Makes Boom Visible In The Night

LED Illumination bar can be installed onto boom to make boom visible in the night, so that drivers can view barrier and boom clearly, this improve safety of both barrier and vehicle. Also LED decorates barrier gate.

### More Features

1. 0.9~6 sec. speed adjustable
2. Quite smooth moving with Max. 6m boom
3. Different types of boom can be changed without replacing any parts
4. Variable frequency controller automatically detects and optimizes boom moving, ensures smooth moving without shake
5. Barrier decelerates in the end of opening and closing to avoid shaking
6. Simplified design, easy installation and maintenance reduces your labor cost
7. Boom automatically open up fully in case of power failure (Optional)
8. Mechanical self-locking the boom, can not lift up the boom by hand
9. Alarm when boom swing-off (Optional)
10. Safety for vehicle--- Anti-hit by Loop Detector (Optional)
11. Safety for vehicle & pedestrian— Anti-hit by IR photocell (Optional)
12. Safety for vehicle & pedestrian— Anti-hit by "Opening Priority"
13. Automatically close in given time (Programmable)
14. Automatically close or open by loop detector (Optional)
15. Enable or disable "Always-open mode" on remote (Optional)
16. Count opening & closing times totally, or count opening or closing times only
17. Anti-condensation in cold climate
18. Transparent plastic covers on control board to protect the board.

## Dimension (mm) Application

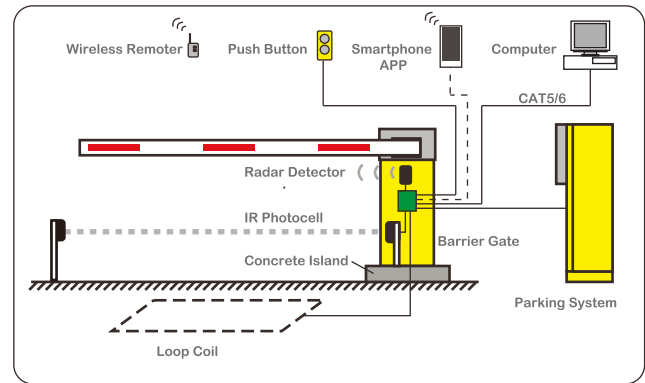
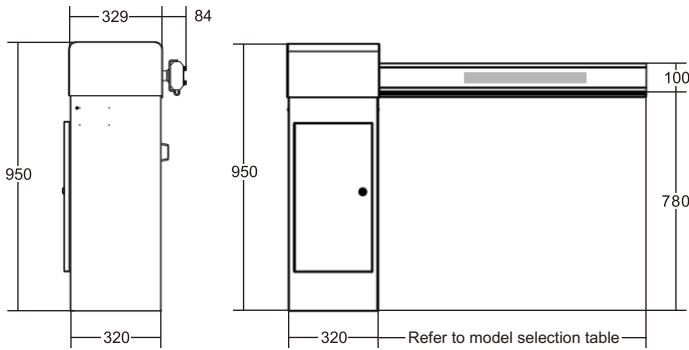

## Technical Parameter

<b>Close/open time</b>	0.9-6 sec. adjustable
<b>Boom</b>	Max. 6mtr. 45×100mm aluminum alloy octagonal boom
<b>Boom</b>	Max. 3mtr. round boom with foam
<b>Boom Direction</b>	Leftward / rightward exchangeable
<b>Power Supply</b>	AC100-240V, 50/60Hz, Max.0.5A
<b>Motor</b>	50W DC24V brushless servo torque motor
<b>Duty Cycle</b>	100% duty cycle
<b>MCBF</b>	10 Million Cycles (Mean Cycles Before Failure)
<b>Max. frequency</b>	15,000 operation cycles per day
<b>Controller</b>	PWM variable frequency servo controller board

<b>Communication Interface</b>	RS-485 or TCP/IP
<b>Wireless Remote</b>	Two Remoters, distance>20m
<b>Housing Material</b>	2mm cold-roller sheet
<b>Housing Painting</b>	Powder coating last 10 years
<b>Protection Rating</b>	IP 54
<b>G.W / N.W</b>	46/44KG
<b>Package Dimension</b>	1100×480×430mm
<b>Dimension</b>	950×320×329mm (H*W*D)
<b>Operating Temperature</b>	-30°C~55°C
<b>Operating Humidity</b>	10% ~ 95%

## Accessories

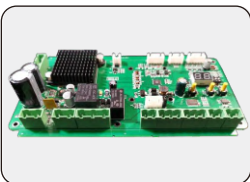

PWM variable frequency servo controller board



Remoter: transmitter, distance>20m

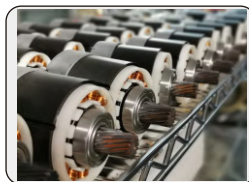

50W DC24V Brushless Servo Torque Motor

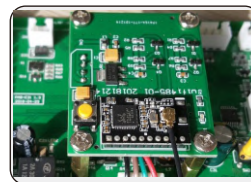

WIFI Module Smartphone control barrier

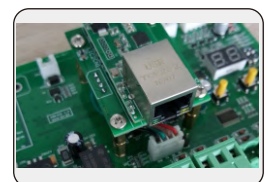

Ethernet Module Make your system control our barrier



Aluminum Alloy Round Boom with Foam



45×100mm Aluminum Alloy Octagonal arm with rubber

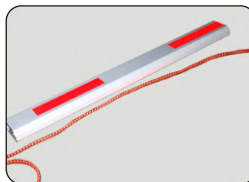

Arm With LED stripe: Green/red, DC12V power

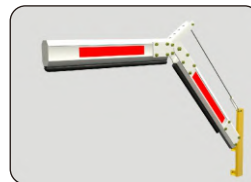

Crank arm



Fence arm

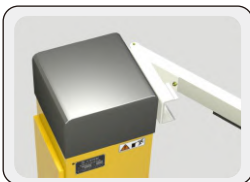

Swing off & alarm module



Ground Induction



Loop Detector



Photocell



Boom Support